

## TORNADO® Rotary Lobe Pumps

The new benchmark for Rotary Lobe Pumps

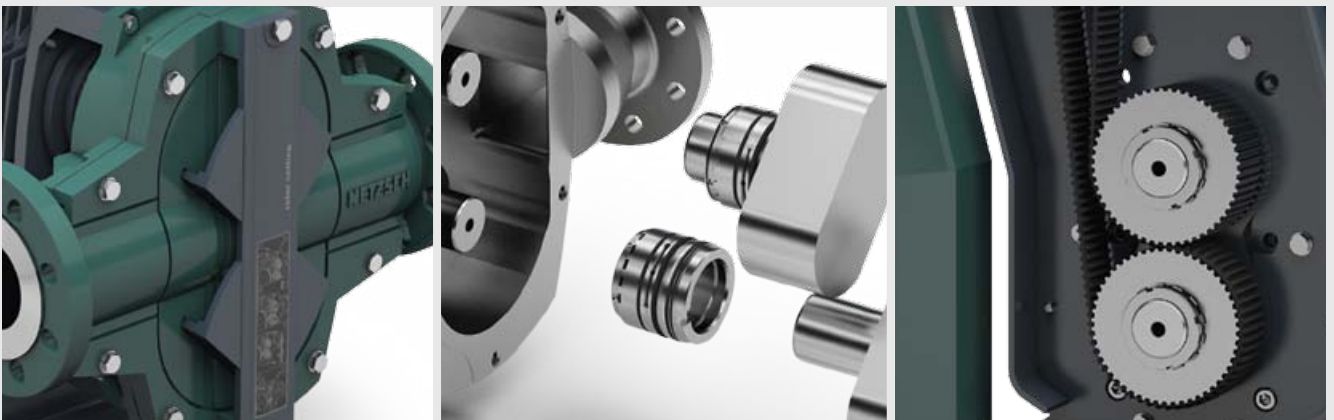

# TORNADO® – High performance, reliability, ease of service

High-performance Rotary Lobe Pumps maximise operational reliability

**NETZSCH TORNADO® self-priming, valveless, positive displacement pumps can be optimally customised to meet specific process and application requirements. They can be used for almost any media on intermittent, continuous or dosing applications.**

TORNADO® advantages are small space requirements due to their compact design, high performance and maximised operational reliability, and the physical separation between the pump head and bearing housing. TORNADO® pumps are particularly service and maintenance friendly; all parts that come into contact with the media are directly accessible without dismantling the pipework or disconnecting the drive.



Pulsation free  
pumping

## Functioning principle

The TORNADO® rotary lobe pump is a positive displacement pump. The pumping action is generated by the contra-rotation of two rotors within the pump chamber which are synchronised externally. The media enters the pump chamber through the inlet port and is carried around the chamber by the rotors to the outlet port where it is discharged.

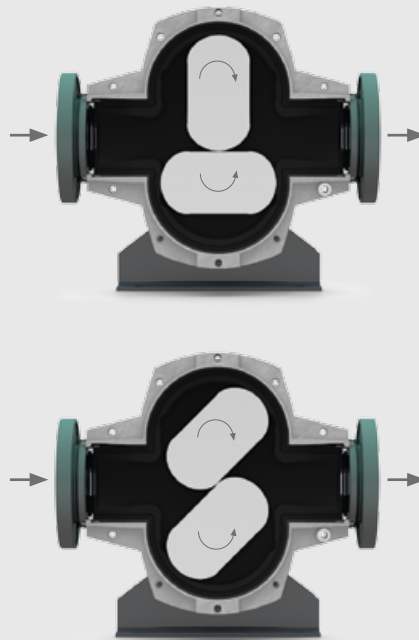

## Characteristics

- Valve free construction
- Self priming
- Suitable for any kind of liquid including media containing gas, solids or fibrous matter
- Suitable for lubricating and non lubricating media
- Pumping media with high or low viscosity
- Handling shear sensitive fluids
- Operating at temperature up to 100°C
- Reversible operation
- Can be serviced without disconnecting pipework
- Tolerance of dry running



# The newly developed TORNADO® T2 – Revolutionary in design and customer benefit

## Stability

### The best maintenance is no maintenance

We have perfected the rotary lobe pump concept by incorporating the tried, tested and proven NETZSCH core competence in the design and manufacture of engineered rubber solutions for the new TORNADO® T2. During the entire pumping cycle only elastomer and metal component surfaces interface within the pump; elastomer to elastomer component surface interfaces, which suffer from excess wear and generate heat, are completely eliminated. Having these dissimilar materials for the static and dynamic pump head components, the elastomeric surfaces are subjected to a lower dynamic loading resulting in less plastic deformation and stress which in turn reduces wear and extends operational life. The use of high quality sealed for life bearings, selected for their load carrying characteristics and long life, combined with the tooth belt drive result in a drive train that can be considered maintenance-free.

## Ease of service

### “Full Service In Place” instead of “Maintenance In Place”

The innovative design of the TORNADO® T2 provides quick and easy access to the pump chamber, including the inlet and outlet ports, by simply removing the cover plate. This provides improved access for inspection, cleaning, service and replacing parts. The service-friendly design of the tooth belt drive means that, should it be necessary, the belt is easy and quick to replace. Benefits of the tooth belt drive system are accuracy of synchronization, elimination of timing gears and oil lubrication, less heat generation and quieter operation.

## Compactness

### Efficiency in the smallest space

Smaller overall dimensions and the innovative design concept of incorporating a timing tooth belt to both synchronise and drive means reduced space is required for both installation and in place servicing representing a cost saving in terms of site utilisation.

## Operational safety

### From GSS<sup>1</sup> to BSS<sup>2</sup>

The proven physical separation between pump chamber and bearing housing guarantees absolute operational safety.

<sup>1</sup> GSS = Gearbox Security System

<sup>2</sup> BSS = Bearing Security System

## PROCESS OPTIMISATION

### COMPACTNESS



### OPERATIONAL

## Cost-effectiveness

### Saves resources and saves money

The revolutionary design of the TORNADO® T2 pump head extends the lifetime and improves the performance of the rotors, the elastomer liners and the mechanical seals. By adopting a modular design approach it reduces the cost of wearing parts extending operating life and significantly reducing the life cycle costs (LCC).

## Process optimisation

### The quality of the components makes the difference

Torsional strength and deflection-resistant high-quality shaft material combined with sealed for life high load characteristic angular contact ball bearings ensure axial and radial shaft stability maintaining pump head rotor fits and clearances resulting in predictable process stability.

## COST-EFFECTIVENESS

## EASE OF SERVICE



## Environmental awareness

### Green is already our corporate colour

The weight of the TORNADO® T2 has been significantly reduced through the choice of materials and innovative component design. This also means the pump consumes less energy. The reduced power requirement, in parallel with increased pump performance, lowers power consumption and so preserves our environment in a sustainable way.

By eliminating the need for oil NETZSCH demonstrate their environmental awareness.

### Drive options

A range of drive options are available to suit specific application and process requirements. For more information see page 9.

STABILITY

SAFETY

# Optimum choice of material – Your application is the decisive factor



Quickest assembly ever

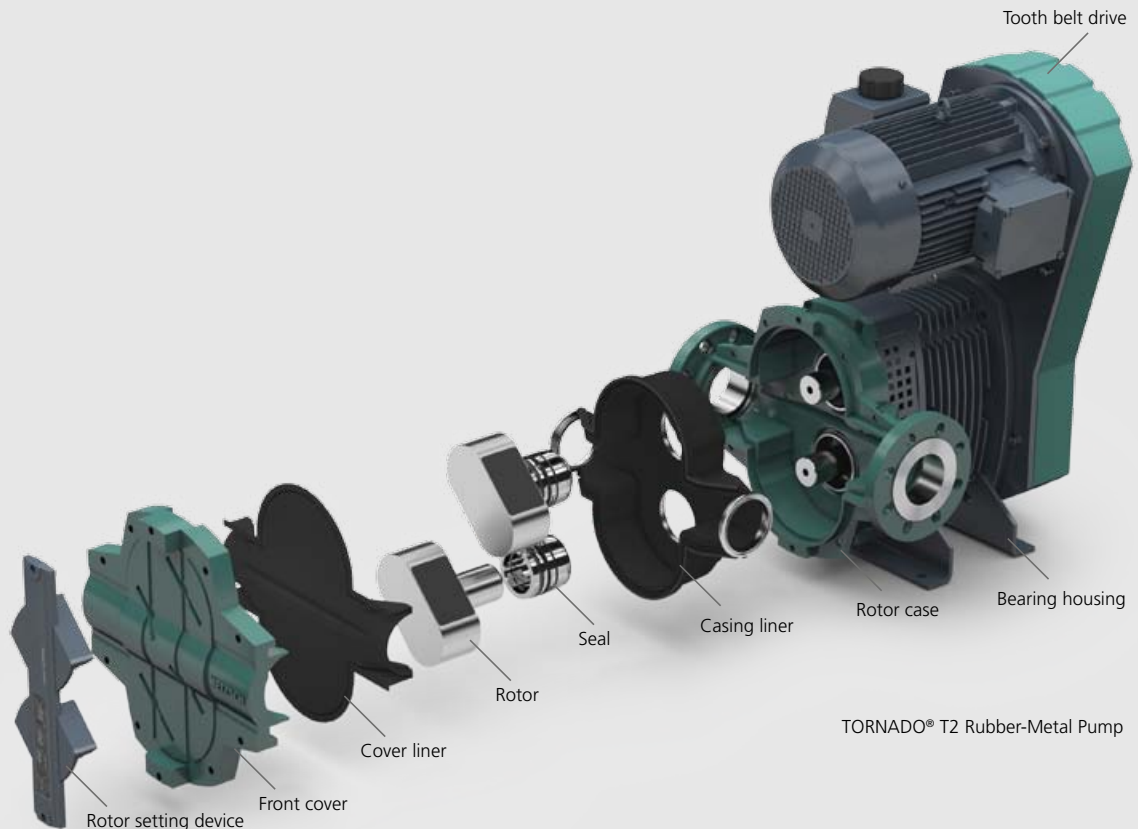

TORNADO® T2 Rubber-Metal Pump

## Stability

### The best maintenance is no maintenance

Plastic deformation and heat generation is reduced by maintaining a uniform elastomeric wall thickness within the pump chamber. Material sections, bearing selection and seal positioning combine to minimize the adverse effects on dimensional changes to pump head geometry due to temperature changes.

The design and geometry of the rotors ensures a high level of durability. With the rotor fixing and drive outside of the pump chamber the rotors can have a completely flat continuous front and back face with no dead areas which eliminates the possibility

of fibrous material becoming trapped and compacted. The mechanical seal design and seal face position eliminates dead areas and allows constant circulation of the media around the faces which ensures that the risk of media entrapment and compaction is minimised.

The TORNADO® T2 all metal pumps can be manufactured from metals offering higher levels of cleanliness, corrosion or abrasion resistance and can therefore be applied to applications demanding the characteristics of these materials, especially in the low sanitary hygienic or chemical market sectors.

## Cost-effectiveness

### The first Rotary Lobe Pump with an elastomer liner reduces life cycle costs (LCC)

For the first time in a rotary lobe pump an elastomer liner is used for all media wetted surfaces of the pump chamber, which is both easy to replace in the event of servicing and significantly less expensive than replacing wear plates and housing parts.

By the correct and most appropriate choice of mating materials and the optimum sizing of the pump head interface geometry, especially with the rubber-metal pump, friction resulting in heat can be minimised. This results in both an energy saving and a longer life for consumable spare parts.

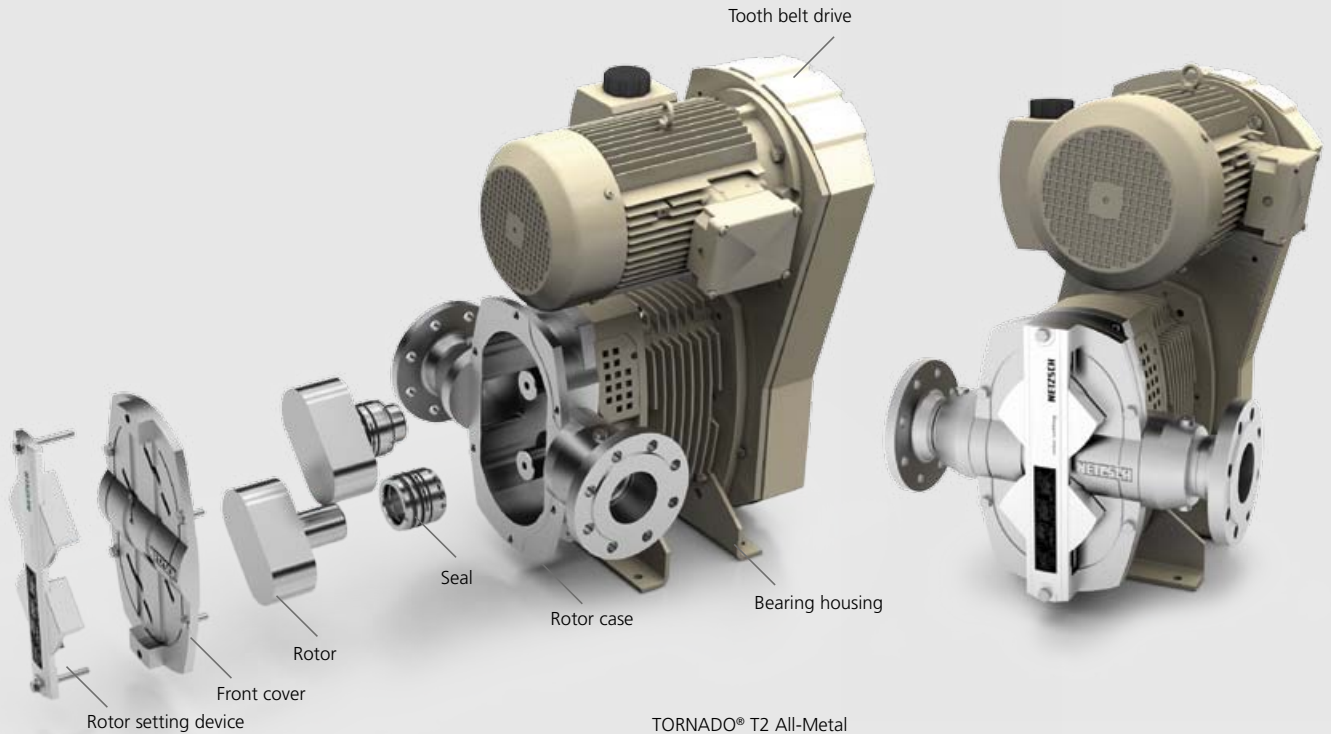

## Ease of service

### “Full Service In Place” instead of “Maintenance In Place”

Servicing a rotary lobe pump has never been so easy and all without the need for any special tools. The rotors can be removed and replaced very easily and quickly because they are not bolted or keyed to the shafts within the pump head but fixed with quick-fit non media wetted taper lock assemblies positioned and accessed outside of the pump head. The geometry of the rotors means that they can be fitted and removed independently. There are no keys dictating a unique rotor position which results in faster, easier and cleaner rotor removal and replacement and for

rotor synchronisation a setting device is included as an integral part of the pump front cover. Benefitting from all these features the service time for the TORNADO® T2 has been reduced to significantly less than half the time required for servicing a conventional rotary lobe pump. The pre-set cartridge mechanical seals are fitted directly into the rotor and mounted on the shafts as one assembly. There are various cartridge mechanical seals available all of which fit into a common housing allowing for seal upgrades without modification.

## Process optimisation

### Maximum reliability through design, material and range of mechanical seals

The revolutionary NETZSCH PRS (Pulsation Reduction System) guarantees an almost pulsation-free discharge that is of benefit in many process applications. Even when used in conjunction with straight bi-lobe rotors, which ensures better solid handling capability and easier maintenance, the NETZSCH PRS provides an almost pulsation-free flow which outperforms the characteristics of complex multi-lobe helical rotors.

The pump chamber and mechanical seal design and position eliminates dead areas, where pump media can collect and compact, making cleaning easier, either manually or by CIP.

# Surprisingly simple – The patented synchronisation of the TORNADO® T2 with a tooth belt drive

## Functioning principle

The drive motor transmits power via a double-sided tooth belt which both drives and synchronises the pump shafts. If required, the drive can be used in conjunction with a frequency converter to achieve a specific flowrate or range of flowrates.



Drive and Synchronisation



Single tooth belt drive

## Stability

### A new application of tried and tested drive technology

An accident causing a complete write-off is inconceivable with this pump. We have replaced the timing gears which have to operate in a managed, maintained environment, with a robust and durable synchronising tooth belt drive. This gives smoothness of operation, load dampening, reduced energy loss and eliminates the need for oil. No more oil filling, draining,

changing, leakages, spillage or disposal reduces down time and increases operation time and provides a cleaner, safer working environment. The simple design of the timing tooth belt drive system reduces down-time for service; the result is that the pump is back on stream in less time, and with less components the pump is less prone to problems.

## Environmental awareness

### TORNADO® T2 – the environment friendly pump

By incorporating a tooth belt drive the pump does not use any oil. There is no chance of any environmental pollution due to spillage or leakage. Our customers benefit from low noise levels and reduced heat in the working area around the pump which corresponds with less energy loss.



## Versatile combination – flexible installation – consistent pumping capacity



Both single and double tooth belt drive arrangements are available providing a wide range of speed reduction ratios.



If required a shaft extension for direct in line coupling to electric motor or diesel engine drive is available.



Power take off (PTO) shaft extension for drive from truck or tractor; twin shaft extensions available where reversible operation is required.

### Drive and design options

A range of drive and design options are available to suit specific application and process requirements. For more information see page 17.

# Optimum operation and process reliability and safety

## From GSS<sup>1</sup> to BSS<sup>2</sup>

- No ingress of the media into the bearing housing in the event of seal failure
- Easy access to seal buffer/quench and barrier/flush connections
- Visual indicator of seal performance

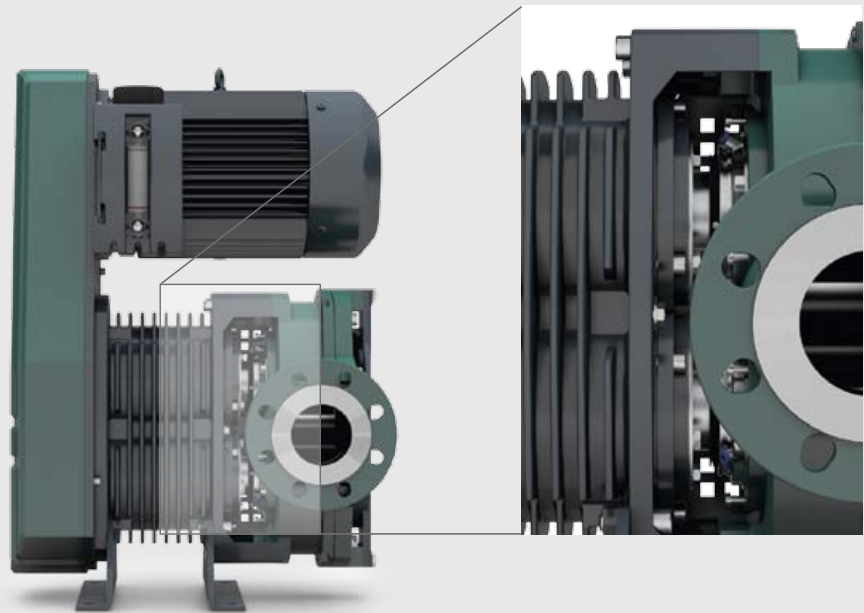

<sup>1</sup> GSS = Gearbox Security System  
<sup>2</sup> BSS = Bearing Security System

## Design and position of mechanical seal: cartridge unit integral with rotor

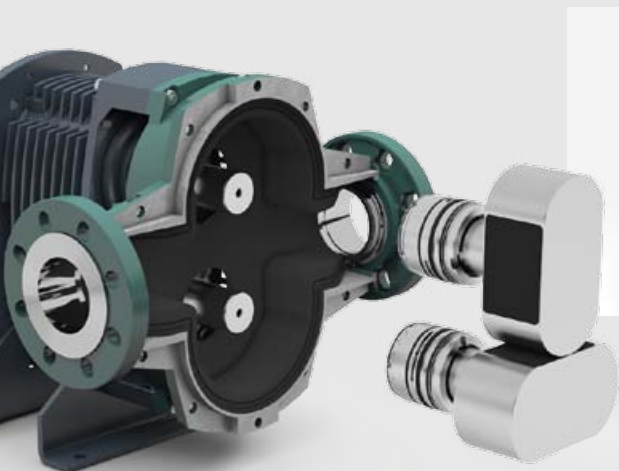

- Uninterrupted and direct flow of media to and around seal faces
- Self draining, no dead areas
- No wear of shafts, the seal is mounted on an integrated rotor sleeve
- Easy assembly and disassembly

## Mechanical seal selection for TORNADO® T2

A pump is only as reliable as its seals. Therefore a range of seals and seal materials are available for the new TORNADO® T2. All seals are of a cartridge design and fit into a common

housing allowing for seal upgrades without modification. The seals are positioned with the seal faces directly in the flowpath through the pump chamber.

### Mechanical seal typically used for agricultural and environmental applications



Single

### Mechanical seal typically used for industrial and general process applications

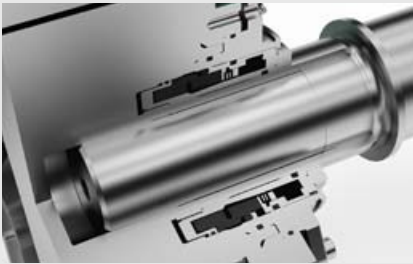

Single

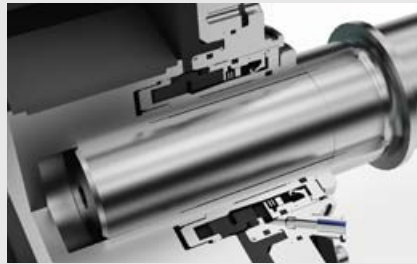

Single for buffer or quench



Double for barrier or flush

# The classic TORNADO® T1 with its proven quality

For more than a decade we have been supplying the classic design NETZSCH TORNADO® T1 rotary lobe pumps. Their extensive use in applications in the Environmental and Energy, Chemical, Pulp and Paper and Oil and Gas sectors for flow rates up to 1000 m<sup>3</sup>/h demonstrate their high performance. Pump size and specification are precisely tailored to suit the characteristics of the pumped media and the operating requirements. Three series with 12 models available provide for flow rates up to 1,000 m<sup>3</sup>/h at discharge pressures up to 6 bar for both intermittent and continuous operation. For higher discharge pressures customised solutions are available.

## Your benefits

- GSS<sup>1</sup> technology for long term reliability
- Maintenance without the need to disconnect the inlet and outlet pipework
- Easy and quick access to the lobes and shaft seals
- Tolerance of running dry
- Short delivery times – all manufacturing 'in-house', large stock of components

<sup>1</sup> Gearbox Security System



Series TORNADO® XLB

Series TORNADO® XB

Series TORNADO® MB

## NETZSCH GSS technology (GSS = Gearbox Security System) – Long-term reliability

The classic TORNADO® T1 rotary lobe pump is of optimal design for each application based on the knowledge and experience gained by Netzsch over many decades of development, design, manufacture and supply of positive displacement pumps into all industries. This experience has founded the development of the NETZSCH GSS technology (Gearbox Security System), which significantly extends operational reliability by physically separating the pump chamber and gearbox.

### Your benefits

- Extended operational reliability
- No ingress of the pumped media into the pump gearbox in the event of a product leaking
- No ingress of pump gearbox oil into the pump chamber
- Easy access to the shaft seal flushing connections

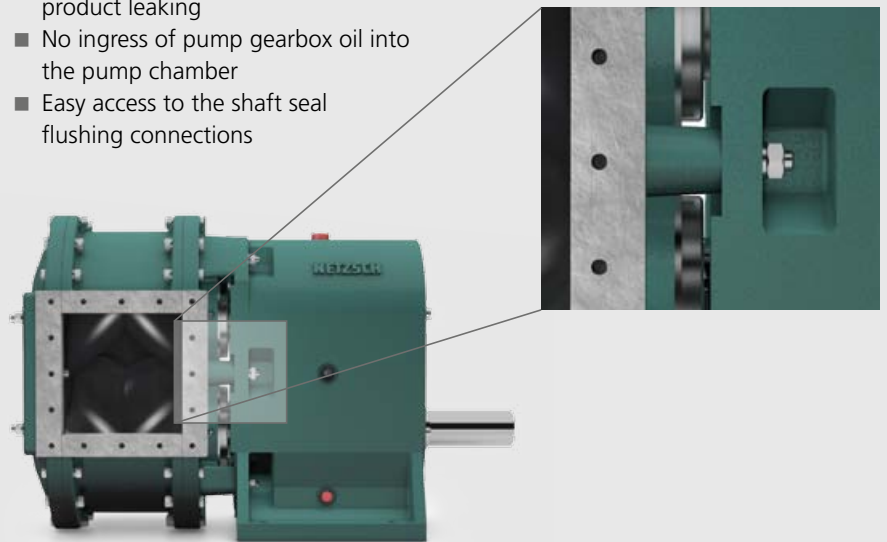

Seals are critical to satisfactory pump performance and the TORNADO® T1 is available with a range of highly engineered sealing solutions designed and selected to extend pump operating life.

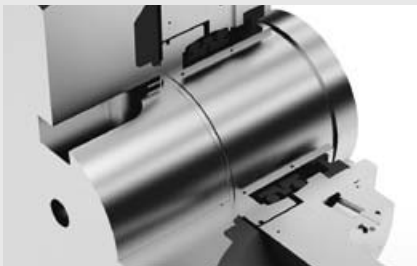

Classic single acting seal

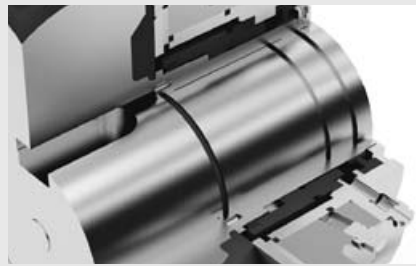

Single for buffer or quench for industrial applications

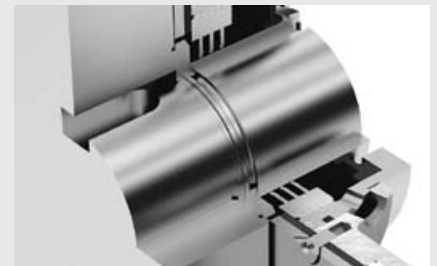

Special seal for demanding applications

# The design of the classic TORNADO® T1

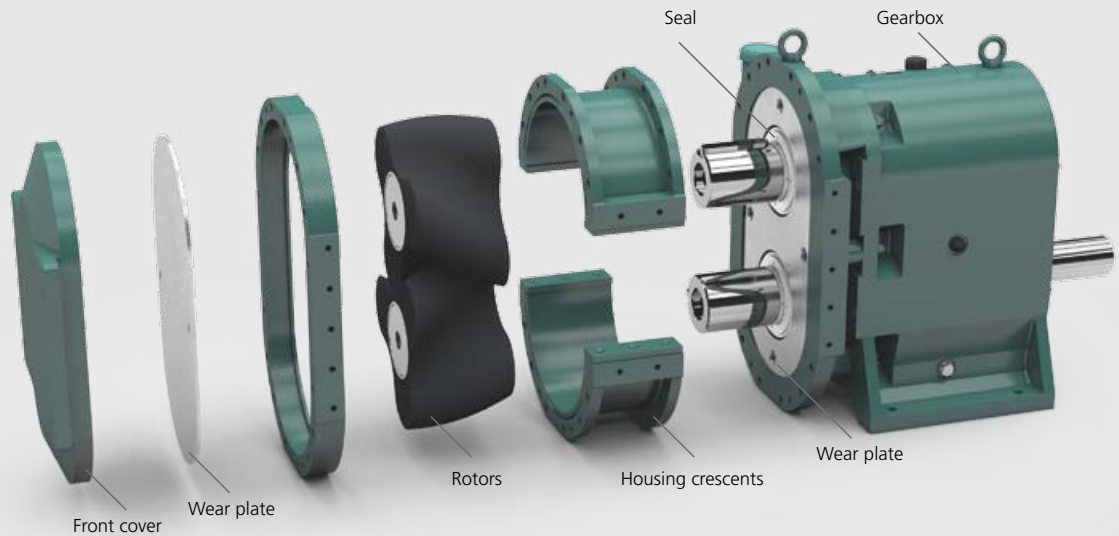

## Front Cover

Rotors, cover seal and product seals can be accessed for inspection, service or replacement by simply removing the front cover. Disassembly of the inlet and outlet pipework and pump housing is not necessary.

## Wear Plates

Abrasion and chemically resistant, replaceable wear plates are fitted both sides of the rotors.

## Rotors

Straight sided or helical rotors are selected to suit individual application requirements. Rotors are available as bi-lobe, tri-lobe or four-lobe and a wide range of materials is available.

## Housing Crescents

Modular construction allows for the crescents to be simply replaced should wear occur. Pump life time can be further extended with the option of replaceable crescent liners.

## Seals

Wide range of product seals and materials are available, which are selected to suit individual application requirements. Seal arrangements include easy access connections for seal quench or flush.

## Gearbox

The patented gearbox design includes NETZSCH GSS-Technology separating the pump head from the gear box which eliminates cross contamination between the pump media and gear box lubricant.

**Pump inlet and outlet adaptors for connection to installation pipework are available in various designs**

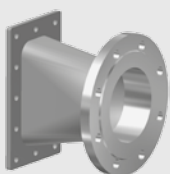

Straight adaptor

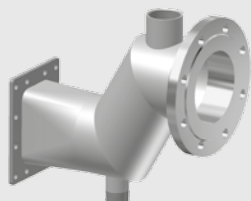

S-shaped adaptor

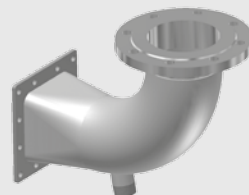

Elbow (90° upwards) adaptor

## Connection options

Adaptors designed to suit specific installations available on request

## The rotors – low-pulsation, smooth pumping of all media

### Rotors in different geometries and materials

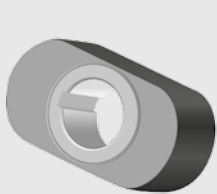

2-lobe straight

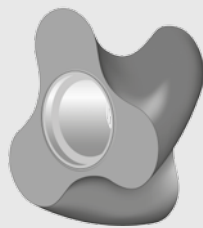

3-lobe helical

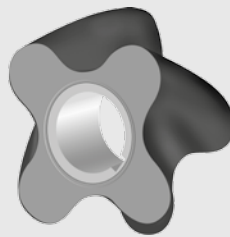

4-lobe helical

The rotor geometry and material are selected for the characteristics of the pumped media. Geometries are available for products which are viscous, abrasive or contain solids. Materials tailored to the media characteristics increase the durability of the rotors and extend service life.

## Range of pump head wetted materials broadens application coverage

For handling chemically corrosive or otherwise aggressive media the TORNADO® T1 pump housing, wear plates, liners and rotor cores are available in suitably resistant materials.

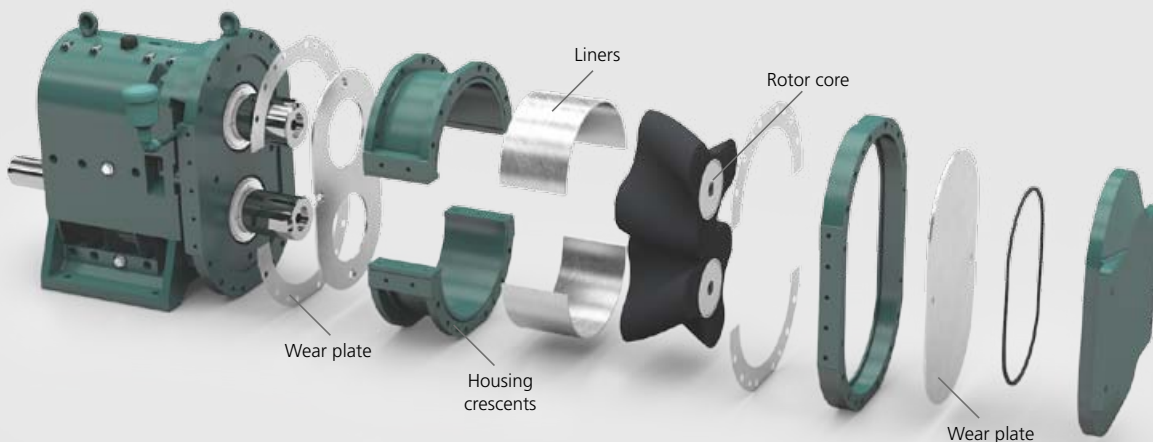

# TORNADO® Rotary Lobe Pumps – Totally reliable everywhere



Feed pump for substrate in a biogas plant. Flowrate up to 40 m<sup>3</sup>/h at pressures up to 2 bar.

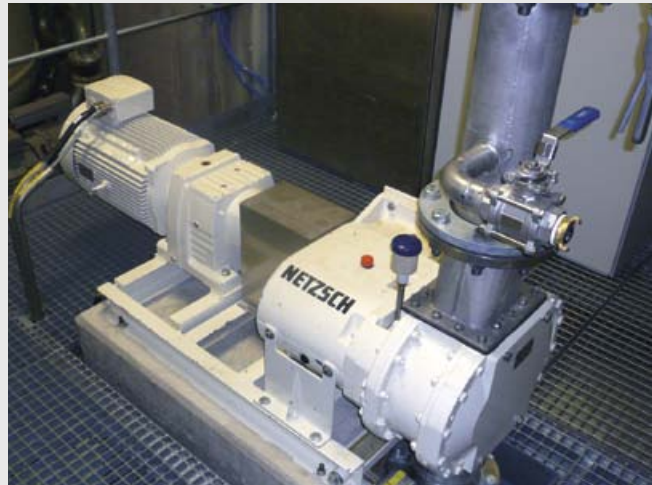

The TORNADO® T1 in use in a paper mill. Kaolin tankers are unloaded at 75 m<sup>3</sup>/h against a pressure of up to 4 bar.



Used in a wastewater treatment plant, the TORNADO® T2 pumps sludge with 2% solid content at a capacity up to 18 m<sup>3</sup>/h against a pressure up to 2 bar.

## Broad application spectrum

TORNADO® rotary lobe pumps can be used for media that has the following characteristics:

- Abrasive, corrosive and fibrous
- Containing solids (max. particle size up to 70 mm)
- Low to high viscosity
- Shear sensitive
- Non-lubricating and lubricating

## Wide capacity and pressure range

- Flowrates up to 1,000 m<sup>3</sup>/h
- Pressures up to 10 bar



## Design versions: The TORNADO® modular system, the optimum solution for every application requirement

TORNADO® pumps are able to transfer media containing solids and fibrous matter. Waste water and sludge can be moved quickly and efficiently whenever and wherever required. Whatever the process the TORNADO® range of sizes,

specifications and materials allows a customised solution for all applications. TORNADO® pumps can be mounted on baseplates, trollies or trailers and the range of drives available include electric motors, diesel engines and hydraulic motors.

### Further information

TORNADO® Mobil  
Brochure NMP · 045

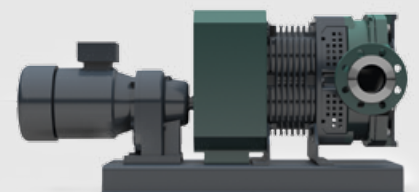
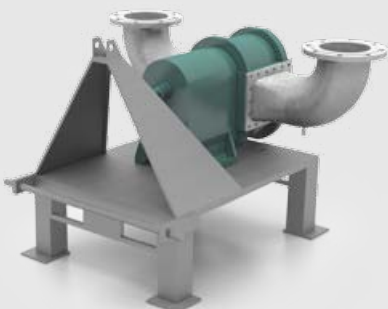
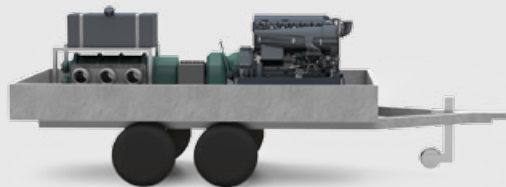
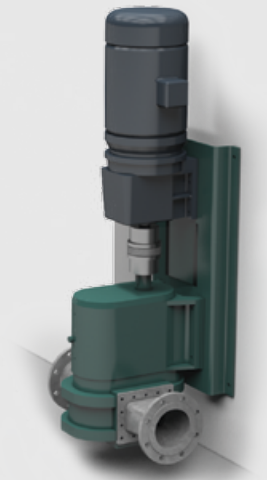
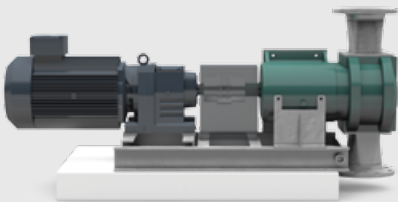

# The ideal pump for your application, available with the accessories that protect your process – it's the combination that counts

Accessories to increase the operational safety of both pump and plant and to prevent downtimes

## Dry running protector

The dry running protection units (STP2A, STP2D) for use with the Tornado rotary lobe pumps operate by monitoring the temperature between rotor and rotor case during normal operation. Should the operating temperature rise over a predetermined set point due to an increase in friction caused by dry running the unit will shut down the pump, thus preventing any damage to the rotor case liner and rotor. The unit controller can be set for two different switch temperatures, for example the first set temperature could be used for the normally pumped media and the second for a different media temperature, for example for a cleaning fluid process.

## Quench pot for single mechanical seals

A quench pot is necessary when the shaft seals need to be operated with a quench, but it is not required that the seal is continuously flushed. The provision of a quench pot would be recommended to prevent dry running of the seals or crystallisation of the pumped media.

## Pressurised flush for double mechanical seals

A double mechanical seal must be used in conjunction with a system providing a pressurised flush or thermo-syphon system. The pressurised flush is required to lubricate the seals, cool the seals and seal area and flush contaminants from the seal chamber. The flush liquid should be compatible with the pumped media, lubricating and have a high specific heat capacity.

The pressure of the flush should be 2bar above the pressure acting on the inboard seal from the pump chamber and flow rate of the flush must also be controlled.

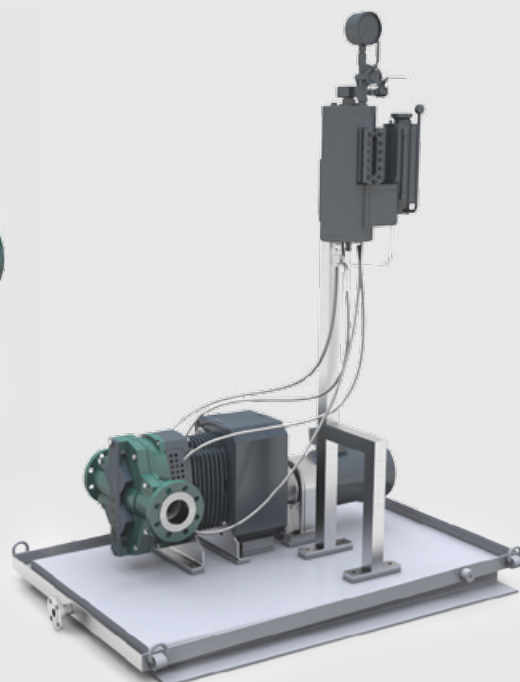

Further accessories

available on request

## Frequency converter

For varying speed and flowrates a frequency converter is available



## Over pressure protection

Bypass line with relief valve for over pressure protection

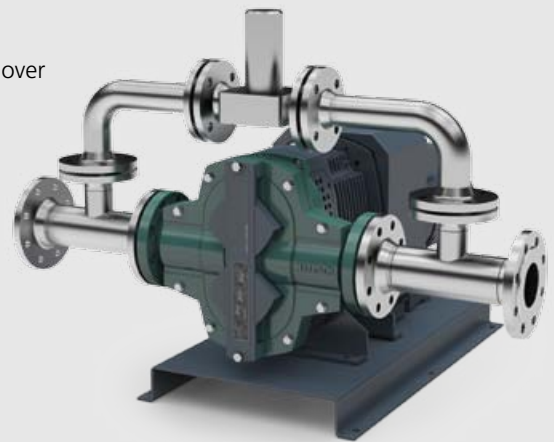

Our product philosophy – your benefit: the best pump for your application

The TORNADO® rotary lobe pump is available in four series with each series offering features and specifications meeting specific market needs.

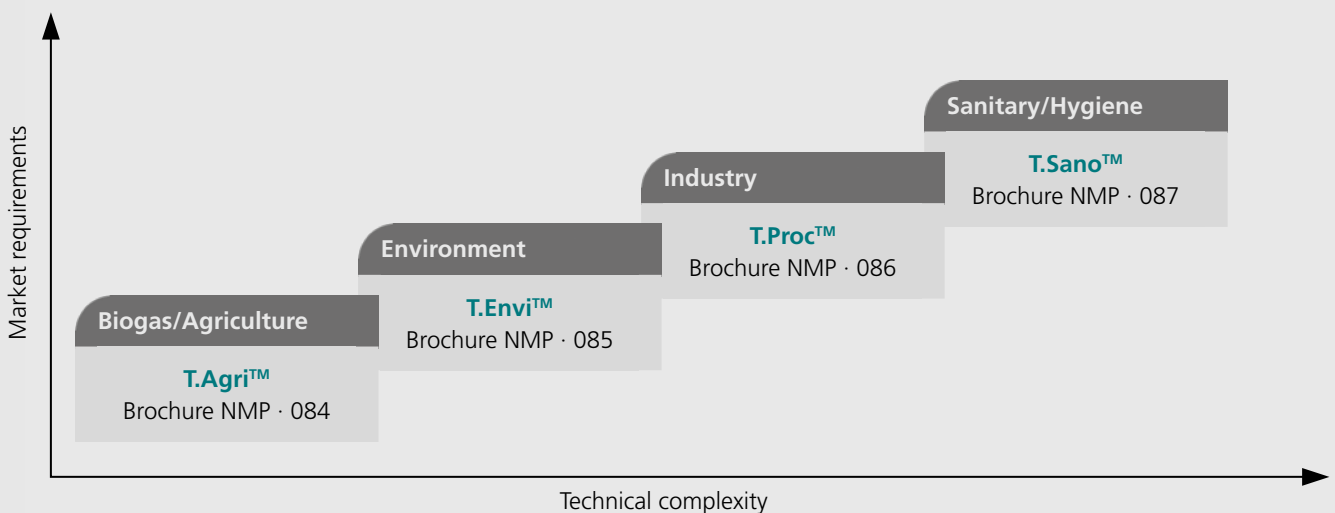

The NETZSCH Group is an owner-managed, internationally operating technology company headquartered in Germany.

The three Business Units – Analyzing & Testing, Grinding & Dispersing and Pumps & Systems – provide tailored solutions for highest-level needs. Over 2,500 employees at 130 sales and production centers in 23 countries across the globe guarantee that expert service is never far from our customers.

The NETZSCH Business Unit Pumps & Systems offers NEMO® progressing cavity pumps, TORNADO® rotary lobe pumps, screw pumps, macerators/grinders, dosing systems and equipment custom built and challenging solutions for different applications on a global base.

NETZSCH Rotary Lobe Team

Tel.: + 49 8638 63-2400  
Fax: + 49 8638 63-92400  
info.tornado@netzsch.com  
www.netzsch.com

NETZSCH Mohnopumpen GmbH  
Geretsrieder Straße 1  
84478 Waldkraiburg  
Germany

**BLUECOMPETENCE**

Alliance Member

Partner of the Engineering Industry  
Sustainability Initiative